



FITTING INSTRUCTIONS FOR CP0457BL
AERO CRASH PROTECTORS
KAWASAKI NINJA ZX-6R 2019



Picture A



Picture B

THIS KIT CONTAINS THE ITEMS PICTURED AND LABELLED BELOW.
DO NOT PROCEED UNTIL YOU ARE SURE ALL PARTS ARE PRESENT.

Please note that the way the kit is packed does not necessarily represent the way of mounting to the bike

THE PARTS SHOWN MAY BE REPRESENTATIVE ONLY (FOR CLARITY OF INSTRUCTIONS ONLY)

TOOLS REQUIRED

- Socket set to include 14 and 17mm socket and wrench.
 - Torque wrench (up to 40Nm).

TOWARDS REAR
OF BIKE



TOWARDS FRONT
OF BIKE

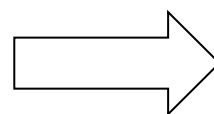
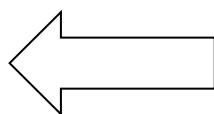

PICTURE C

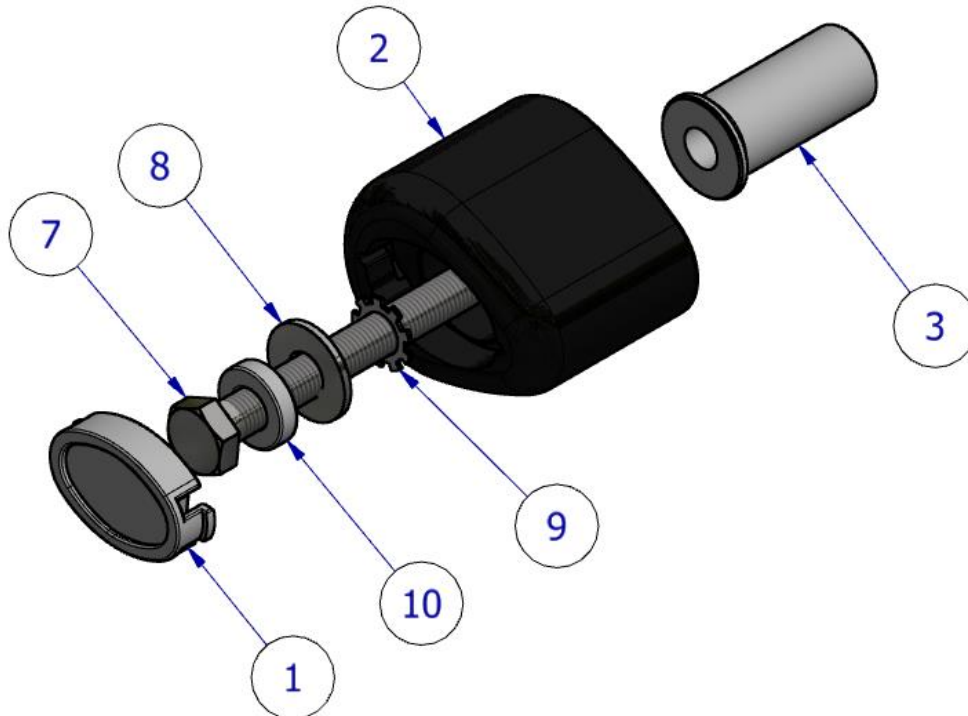

LEFT HAND SIDE

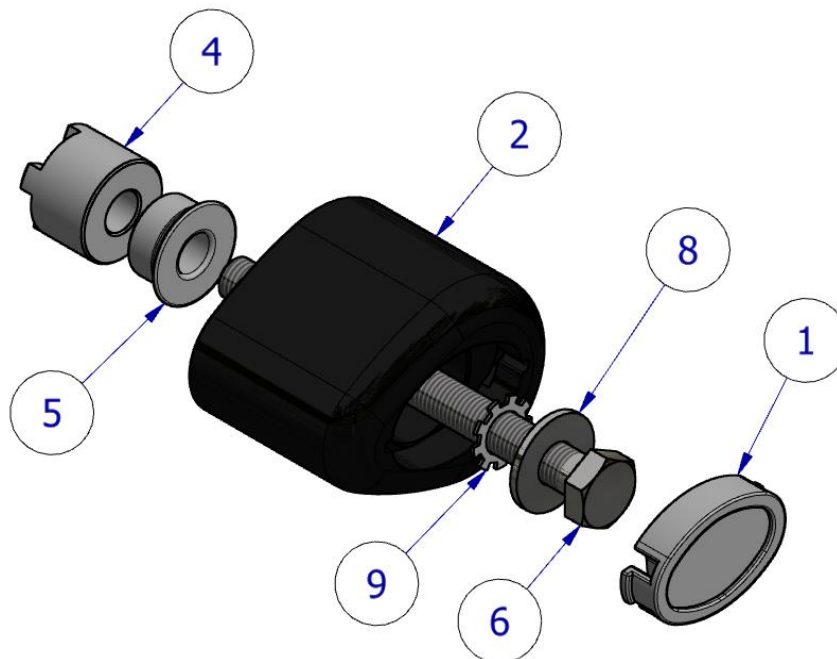

RIGHT HAND SIDE



LEGEND

- ITEM 1= CRASH PROTECTOR CAPS (BC0002) (x2).
 ITEM 2= CRASH PROTECTOR (B0063 with CS066) (x2).
 ITEM 3= SPACER LHS (S1165) (x1).
 ITEM 4= CASTELLATED SPACER RHS (S0218) (20mm LONG) (x1).
 ITEM 5= SPACER RHS (S0146) (11.7mm LONG) (x1).
 ITEM 6= M10x1.25x110mm LONG HEX HEADED BOLT R-H-S (x1).
 ITEM 7= M10x1.25x120mm LONG HEX HEADED BOLT L-H-S (x1).
 ITEM 8= M10 WASHER (x1).
 ITEM 9= LOCK-WASHERS (LW0001) (x2)
 ITEM 10 = S0293 SPACER (5mm LONG) (x1)

Please note that in cases where kits are packed with rubber washers holding the components onto the bolt – *the rubber washers should be thrown away!*

FITTING INSTRUCTIONS

Near side (left side as you sit on bike)

- Remove the engine-mounting bolt arrowed in picture 'A' (using a 14mm socket).
- Slide one S0293 Spacer (item 10) over the longer M10x120mm bolt (Item 7) so the spacer sits against the head of the bolt.
- Slide an M10 washer (item 8) over the bolt so washer sits against the spacer just fitted.
- Slide one of the serrated locking washers (item 9) onto the bolt so it sits against washer just fitted.
- Next slide bolt, spacer and washers through a crash protector (item 2) so head of bolt goes into counter-bore in the crash protector.
- Next slide the longest spacer (item 3) over bolt so larger diameter sits against the crash protector (the amount of bolt protruding from assembly should be the same as the original engine mounting bolt).
- Offer this assembly up to frame mount and tighten bolt until you feel some compression from inside the protector using a 17mm socket and wrench. PLEASE NOTE THE CRASH PROTECTOR MUST BE POSITIONED AS IN PICTURE 'C' ABOVE WITH BIGGER END TOWARD FRONT OF BIKE. Turn a little more so that you feel the compression increase slightly. Then apply a quarter turn. Do not over-tighten as damage can occur to the bike. Do not exceed 40Nm of torque.
- If not already fitted, fit bubble sticker into recess of the crash protector cap (item 1).
- Fit the crash protector cap into the crash protector.

Off side (right side as you sit on bike)

- Remove the engine-mounting bolt arrowed in picture 'B' (using a 14mm socket).
- Slide one M10 plain washer (item 8) over the shorter M10x110mm long hexagon headed bolt (item 6) so washer sits against head of bolt.
- Slide one of the serrated locking washers (item 9) onto the bolt so it sits against washer just fitted.

R&G Racing

Unit 1, Shelley's Lane, East Worldham, Alton, Hampshire, GU34 3AQ

Tel: +44 (0)1420 89007 Fax: +44 (0)1420 87301 www.rg-racing.com Email: info@rg-racing.com



- Next slide bolt with washers through remaining crash protector (item 2) so head of bolt goes into counter-bore in the crash protector.
- Next slide the remaining shorter spacer (item 5) over bolt so larger diameter sits against the crash protector.
- Fit the castellated spacer (item 4) (20mm long) over the original engine/frame adjustment nut so the castellated sections interlock (the amount of bolt protruding from spacer should be the same as the original engine mounting bolt).
- Offer this assembly up to frame mount and tighten bolt until you feel some compression from inside the protector using a 17mm socket and wrench. **PLEASE NOTE THE CRASH PROTECTOR MUST BE POSITIONED AS IN PICTURE 'C' ABOVE WITH BIGGER END TOWARD FRONT OF BIKE.** Turn a little more so that you feel the compression increase slightly. Then apply a quarter turn. Do not over-tighten as damage can occur to the bike. Do not exceed 40Nm of torque.
- If not already fitted fit bubble sticker into recess of the crash protector cap (item 1).
- Fit the crash protector cap into the crash protector.

ISSUE 4 22/05/2019 (DM)

CONSUMER NOTICE

The catalogue description and any exhibition of samples are only broad indications of the Products and R&G may make design changes which do not diminish their performance or visual appeal and supplying them in such state shall conform to the order. The Buyer acknowledges no representation or warranty (other than as to title) has been given or will apply to the Products other than those in R&G's order or confirmation and the Buyer confirms it has chosen the Products as being of merchantable quality and suitable for its particular purposes. Where R&G fits the Products or undertakes other services it shall exercise reasonable skill and care and rectify any fault free of charge unless the workmanship has been disturbed. The Buyer is responsible for ensuring that the warranty on the motorcycle is not affected by the fitting of the Products. On return of any defective Products R&G shall at its option either supply a replacement or refund the purchase money but shall not be liable if the Products have been modified or used or maintained otherwise than in accordance with R&G's or manufacturer's instructions and good engineering practice or if the defect arises from accident or neglect. Other than identified above and subject to R&G not limiting its liability for causing death and personal injury, it shall not be liable for indirect or consequential loss and otherwise its liability shall be limited to the amounts paid by the Buyer for the Products or the fitting or service concerned. These terms do not affect the Buyer's statutory rights.

R&G RACING RETURNS POLICY (NON-FAULTY GOODS)

Returns must be pre-authorized (if not pre-authorized the return will be rejected). Goods may only be returned direct to us if they were purchased direct from us (customer must prove if necessary). Otherwise to be returned to original vendor. Goods must be in re-sellable condition, in the opinion of R&G Racing. All returns are subject to a 25% restocking and handling fee (25% of the gross value exc. P&P – at the prevailing price at time of purchase). The customer must pay any and all carriage charges. No returns of discontinued products, unless within 14 days of purchase. This policy does not affect your statutory rights and does not refer to faulty goods.



NOTICE DE MONTAGE CP0457BL
PROTECTIONS CRASH
KAWASAKI NINJA ZX-6R 2019



Photo A



Photo B

Le kit contient les articles exposés ci-dessous, vérifier que toutes les pièces soient présentes avant de procéder au montage.

La façon dont le kit est emballé ne correspond pas forcément à la façon de monter les pièces sur la moto.

LES PARTIES PRÉSENTÉES PEUVENT ÊTRE UNIQUEMENT REPRESENTATIVES (POUR LA CLARTE DES INSTRUCTIONS UNIQUEMENT)

OUTILS REQUIS

- Clé à cliquet + douille 14mm et 17mm.
- Clé dynamométrique (jusqu'à 40Nm).

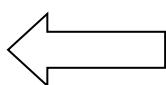

ARRIÈRE MOTO



PHOTO C

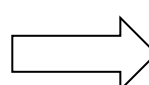

AVANT MOTO

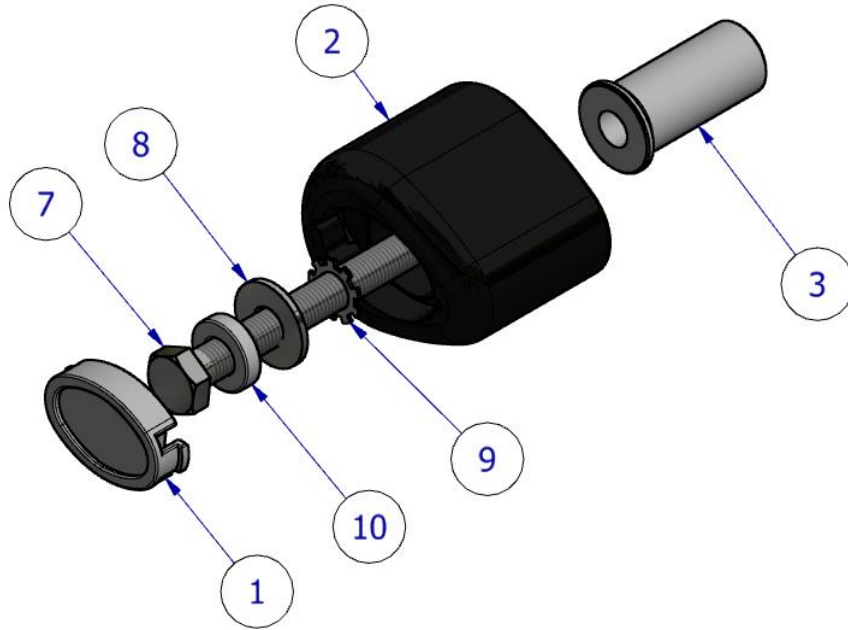

CÔTÉ GAUCHE

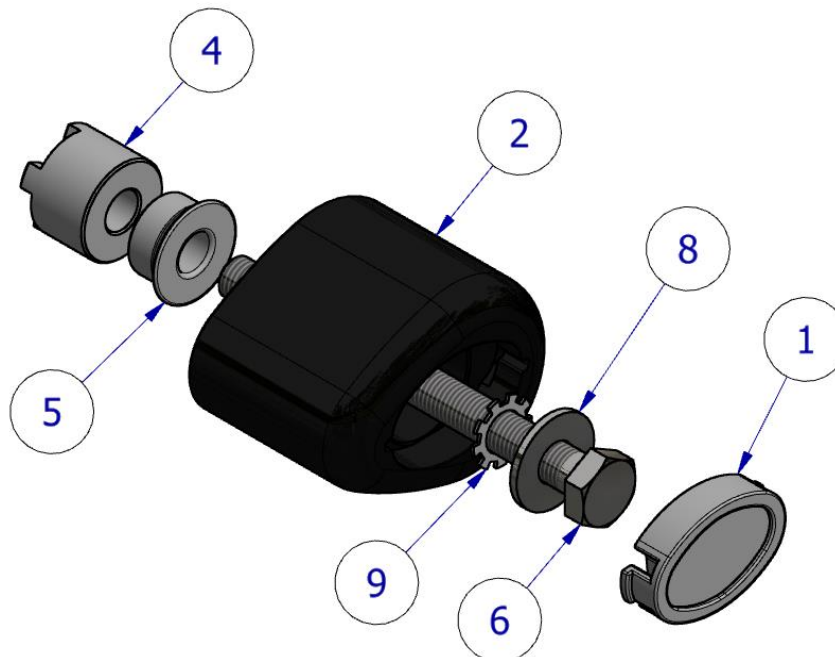

CÔTÉ DROIT



LÉGENDE

- ARTICLE 1= CAPUCHONS DE PROTECTION CRASH (BC0002) (x2).
ARTICLE 2= PROTECTION CRASH (B0063 avec CS066) (x2).
ARTICLE 3= ENTRETOISE GAUCHE (S1165) (x1).
ARTICLE 4= ENTRETOISE DROITE (S0218) (20mm DE LONG) (x1).
ARTICLE 5= ENTRETOISE DROITE (S0146) (11.7mm DE LONG) (x1).
ARTICLE 6= M10x1.25x110mm BOULON DROIT (x1).
ARTICLE 7= M10x1.25x120mm BOULON GAUCHE (x1).
ARTICLE 8= M10 RONDELLE (x1).
ARTICLE 9= RONDELLES DE BLOCAGE (LW0001) (x2)
ARTICLE 10 = S0293 ENTRETOISE (5mm DE LONG) (x1)

Notez que si les kits sont emballés avec des rondelles en caoutchouc servant à tenir les composants, *ces rondelles doivent être jetées !*

NOTICE DE MONTAGE

Côté gauche (Lorsqu'on est assis sur la moto)

- Enlever le boulon de fixation moteur, voir photo 'A' (en utilisant une clé à cliquet + douille 14mm).
- Glisser une entretoise S0293 (article 10) sur le boulon M10x120mm (article 7) de façon à ce que l'entretoise se place contre la tête du boulon.
- Glisser une rondelle M10 (article 8) sur le boulon de façon à ce que la rondelle se place contre l'entretoise tout juste insérée.
- Glisser une rondelle de blocage (article 9) sur le boulon de façon à ce qu'elle se place contre la rondelle tout juste insérée.
- Glisser ensuite le boulon, l'entretoise et les rondelles dans la protection crash (article 2) de façon à ce que la tête du boulon se place dans le contre alésage de la protection.
- Glisser ensuite la longue entretoise (article 3) sur le boulon de façon à ce que le diamètre le plus large se place contre la protection crash (la longueur de boulon dépassant de l'ensemble doit être identique à celle du boulon de fixation d'origine).
- Monter l'ensemble sur le support cadre puis serrer le boulon jusqu'à ce que vous sentiez une légère compression à l'intérieur de la protection, en utilisant une clé à cliquet de 17mm. **LA PROTECTION DOIT ETRE POSITIONNEE AVEC LE CÔTÉ ARRONDI LE PLUS GROS EN DIRECTION DE L'AVANT DE LA MOTO.** Tourner un peu plus afin d'accentuer légèrement la compression. Faire un quart de tour. Serrer à 40Nm de couple.
- Si cela n'est pas déjà fait, insérer le sticker dans le creux du bouchon de protection crash (article 1).
- Insérer le bouchon de protection crash dans la protection.

Côté droit (Lorsqu'on est assis sur la moto)

- Enlever le boulon de fixation moteur, voir photo 'A' (en utilisant une clé à cliquet + douille 14mm).
- Glisser une rondelle M10 (article 8) sur le boulon plus court M10x110mm (article 6) de façon à ce que la rondelle se place contre la tête du boulon.



- Glisser une rondelle de blocage (article 9) sur le boulon de façon à ce qu'elle se place sur la rondelle tout juste insérée.
- Glisser ensuite le boulon avec ses rondelles dans la protection crash restante (article 2) de façon à ce que la tête du boulon se place dans le contre alésage de la bobine de protection crash.
- Glisser ensuite l'entretoise plus courte restante (article 5) sur le boulon de façon à ce que le diamètre plus large se place contre la protection crash.
- Insérer l'entretoise crénelée (article 4) (20mm de long) sur l'écrou moteur/cadre d'ajustement de façon à ce que les sections crénelées s'emboîtent (la longueur de boulon dépassant de l'entretoise doit être la même que le boulon de fixation moteur d'origine).
- Monter l'ensemble sur le support cadre puis serrer le boulon jusqu'à ce que vous sentiez une légère compression à l'intérieur de la protection, en utilisant une clé à cliquet de 17mm. **LA PROTECTION DOIT ETRE POSITIONNEE AVEC LE CÔTÉ ARRONDI LE PLUS GROS EN DIRECTION DE L'AVANT DE LA MOTO.** Tourner un peu plus afin d'accentuer légèrement la compression. Faire un quart de tour. Serrer à 40Nm de couple.
- Si cela n'est pas déjà fait, insérer le sticker dans le creux du bouchon de protection crash (article 1).
- Insérer le bouchon de protection crash dans la protection.

ISSUE 4 22/05/2019 (DM)

CONSUMER NOTICE

The catalogue description and any exhibition of samples are only broad indications of the Products and R&G may make design changes which do not diminish their performance or visual appeal and supplying them in such state shall conform to the order. The Buyer acknowledges no representation or warranty (other than as to title) has been given or will apply to the Products other than those in R&G's order or confirmation and the Buyer confirms it has chosen the Products as being of merchantable quality and suitable for its particular purposes. Where R&G fits the Products or undertakes other services it shall exercise reasonable skill and care and rectify any fault free of charge unless the workmanship has been disturbed. The Buyer is responsible for ensuring that the warranty on the motorcycle is not affected by the fitting of the Products. On return of any defective Products R&G shall at its option either supply a replacement or refund the purchase money but shall not be liable if the Products have been modified or used or maintained otherwise than in accordance with R&G's or manufacturer's instructions and good engineering practice or if the defect arises from accident or neglect. Other than identified above and subject to R&G not limiting its liability for causing death and personal injury, it shall not be liable for indirect or consequential loss and otherwise its liability shall be limited to the amounts paid by the Buyer for the Products or the fitting or service concerned. These terms do not affect the Buyer's statutory rights.

R&G RACING RETURNS POLICY (NON-FAULTY GOODS)

Returns must be pre-authorized (if not pre-authorized the return will be rejected). Goods may only be returned direct to us if they were purchased direct from us (customer must prove if necessary). Otherwise to be returned to original vendor. Goods must be in re-sellable condition, in the opinion of R&G Racing. All returns are subject to a 25% restocking and handling fee (25% of the gross value exc. P&P – at the prevailing price at time of purchase). The customer must pay any and all carriage charges. No returns of discontinued products, unless within 14 days of purchase. This policy does not affect your statutory rights and does not refer to faulty goods.



MONTAGEANLEITUNG FÜR CP0457BL
AERO STURZPADS
KAWASAKI NINJA ZX-6R 2019



Abbildung A



Abbildung B

ALLE KIT-TEILE SIND UNTEN ABGEBILDET UND GEKENNZEICHNET.
BEVOR SIE MIT DER MONTAGE BEGINNEN, ÜBERPRÜFEN SIE,
DASS ALLE TEILE VORHANDEN SIND.

Hinweis: Die Verpackung der Teile stellt nicht die Reihenfolge der Montage dar.

DIE UNTEN ABGEBILDETEN TEILE DIENEN LEDIGLICH ZUR ERKLÄRUNG

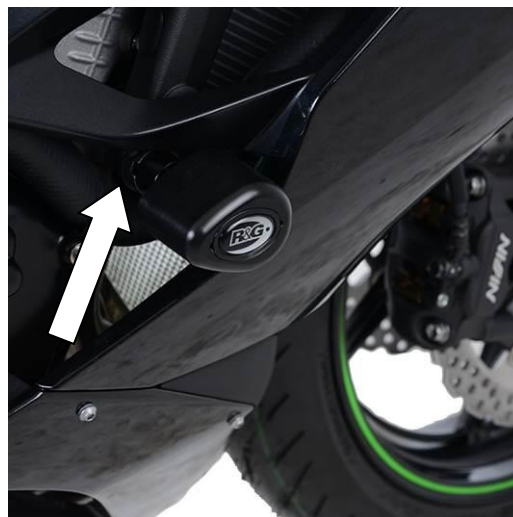
SIE BENÖTIGEN FOLGENDES WERKZEUG

- Steckschlüsselsatz inkl. 14 & 17mm Steckschlüssel
 - Drehmomentschlüssel (bis 40Nm)

MOTORRAD
HINTEN



MOTORRAD
VORNE



ABBILDUNG C



LINKE SEITE

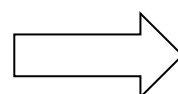
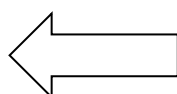
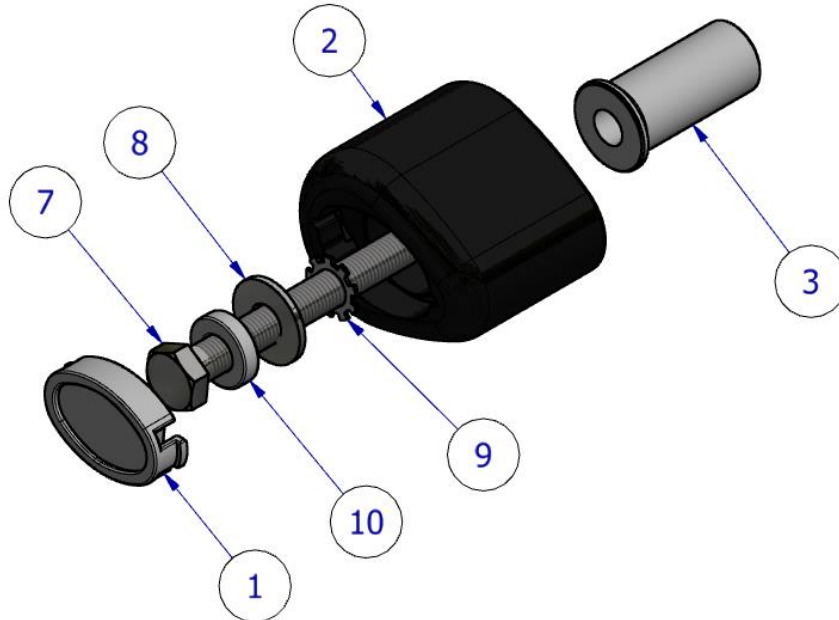
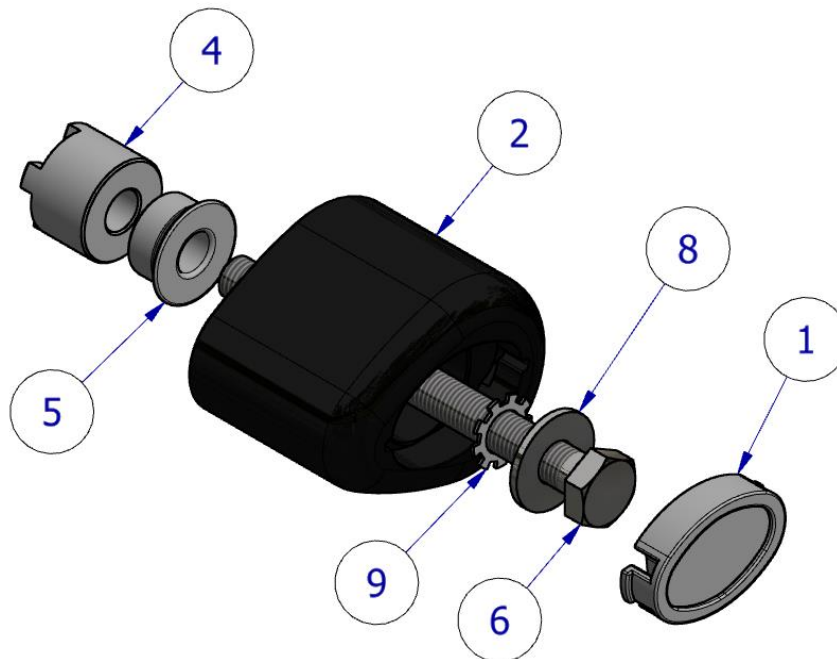

RECHTE SEITE



LIEFERUMFANG

- ARTIKEL 1= STURZPAD-SCHUTZKAPPEN (BC0002) (x2)
 ARTIKEL 2= STURZPAD (B0063 with CS066) (x2)
 ARTIKEL 3= DISTANZHALTER LINKE SEITE (S1165) (x1)
 ARTIKEL 4= KRONENFÖRMIGER DISTANZHALTER RECHTE SEITE (S0218) (20mm Länge) (x1)
 ARTIKEL 5= DISTANZHALTER RECHTE SEITE (S0146) (11,7mm LÄNGE) (x1)
 ARTIKEL 6= M10x1,25x110mm SECHSKANTSCHRAUBE RECHTE SEITE (x1)
 ARTIKEL 7= M10x1,25x120mm SECHSKANTSCHRAUBE LINKE SEITE (x1)
 ARTIKEL 8= M10 UNTERLEGSSCHEIBE (x1)
 ARTIKEL 9= ZAHNSCHEIBE (LW0001) (x2)
 ARTIKEL 10 = DISTANZHALTER S0293 (5mm LÄNGE) (x1)

Hinweis für Kits mit Plastikunterlegscheiben an den Schrauben – *Diese Plastikunterlegscheiben werden nicht für den Einbau benötigt!*

MONTAGEANLEITUNG

Linke Seite (in Fahrtrichtung)

- Entfernen Sie die Montageschraube für den Motor, die in Abbildung 'A' mit einem Pfeil gekennzeichnet ist (benutzen Sie einen 14mm Steckschlüssel).
- Schieben Sie einen S0293 Distanzhalter (Artikel 10) über die längere M10x120mm Schraube (Artikel 7), so dass der Distanzhalter am Schraubenkopf anliegt.
- Scheiben Sie eine M10 Unterlegscheibe (Artikel 8) über die Schraube, sodass sie am soeben montierten Distanzhalter anliegt.
- Eine Zahnscheibe (Artikel 9) nehmen und zur gerade montierten Unterlegscheibe hochschieben.
- Als nächstes, die Schraube, den Distanzhalter und die Unterlegscheiben in ein Sturzpad (Artikel 2) einführen, so dass der Schraubenkopf in die Gegenbohrung des Sturzpads passt.
- Danach den längeren Distanzhalter (Artikel 3) über die Schraube schieben, so dass der große Durchmesser am Sturzpad anliegt (die Schraube sollte genauso weit von der Einheit hervorstehen wie bei der original Montageschraube für den Motor).
- Die Einheit an die Rahmenhalterung ansetzen und die Schraube mit einem 17mm Steckschlüssel festziehen, bis Sie etwas Druck vom Inneren des Sturzpads spüren. **BITTE DARAUF ACHTEN, DASS DAS STURZPAD WIE IN ABBILDUNG 'C' POSITIONIERT IST – DAS GRÖßERE ENDE DES STURZPADS ZUM VORDERTEIL DES MOTORRADS GERICHTET.** Noch etwas drehen, bis Sie merken, dass der Druck sich leicht erhöht, dann noch eine Vierteldrehung anwenden. Nicht überdrehen – dies kann zu einer Beschädigung des Motorrades und der Schraube führen. 40 Nm Anzugsmoment nicht überschreiten!
- Wenn noch nicht bereits montiert, montieren Sie den Bubble-Aufkleber in der Vertiefung der Sturzpad-Schutzkappe (Artikel 1).
- Montieren Sie die Schutzkappe am Sturzpad.



Rechte Seite (in Fahrtrichtung)

- Entfernen Sie die Montageschraube für den Motor, die in Abbildung 'B' mit einem Pfeil gekennzeichnet ist (benutzen Sie einen 14mm Steckschlüssel).
- Nehmen Sie die kurze M10 x 110 mm Sechskantschraube (Artikel 6) und eine M10 Unterlegscheibe (Artikel 8). Schieben Sie die Unterlegscheibe bis zum Schraubenkopf hoch
- Eine Zahnscheibe (Artikel 9) nehmen und zur gerade montierten Unterlegscheibe hochschieben.
- Die Schraube mit den Unterlegscheiben in ein Sturzpad (Artikel 2) einführen, so dass der Schraubenkopf in die Gegenbohrung passt.
- Danach den kurzen Distanzhalter (Artikel 5) über die Schraube zum Sturzpad hochschieben, so dass der große Durchmesser am Sturzpad anliegt.
- Montieren Sie den kronenförmigen Distanzhalter (Artikel 4) (20mm Länge) an der original Motor/Rahmen-Verstellmutter, sodass die kronenförmige Teile ineinander greifen (die Schraube sollte genauso weit vom Distanzhalter hervorstehen wie bei der original Montageschraube für den Motor).
- Die Einheit an die Rahmenhalterung ansetzen und Rahmeneinsatz und die Schraube mit einem 17mm Steckschlüssel festziehen, bis Sie etwas Druck vom Inneren des Sturzpads spüren. **BITTE DARAUF ACHTEN, DASS DAS STURZPAD WIE IN ABBILDUNG 'C' POSITIONIERT IST – DAS GRÖßERE ENDE DES STURZPADS ZUM VORDERTEIL DES MOTORRADS GERICHTET.** Noch etwas drehen, bis Sie merken, dass der Druck sich leicht erhöht, dann noch eine Vierteldrehung anwenden. Nicht überdrehen – dies kann zu einer Beschädigung des Motorrades und der Schraube führen. 40 Nm Anzugsdrehmoment nicht überschreiten!
- Wenn noch nicht bereits montiert, montieren Sie den Bubble-Aufkleber in der Vertiefung der Sturzpad-Schutzkappe (Artikel 1).
- Montieren Sie die Schutzkappe am Sturzpad.

AUSGABE 4 22/05/2019 (DM)

CONSUMER NOTICE

The catalogue description and any exhibition of samples are only broad indications of the Products and R&G may make design changes which do not diminish their performance or visual appeal and supplying them in such state shall conform to the order. The Buyer acknowledges no representation or warranty (other than as to title) has been given or will apply to the Products other than those in R&G's order or confirmation and the Buyer confirms it has chosen the Products as being of merchantable quality and suitable for its particular purposes. Where R&G fits the Products or undertakes other services it shall exercise reasonable skill and care and rectify any fault free of charge unless the workmanship has been disturbed. The Buyer is responsible for ensuring that the warranty on the motorcycle is not affected by the fitting of the Products. On return of any defective Products R&G shall at its option either supply a replacement or refund the purchase money but shall not be liable if the Products have been modified or used or maintained otherwise than in accordance with R&G's or manufacturer's instructions and good engineering practice or if the defect arises from accident or neglect. Other than identified above and subject to R&G not limiting its liability for causing death and personal injury, it shall not be liable for indirect or consequential loss and otherwise its liability shall be limited to the amounts paid by the Buyer for the Products or the fitting or service concerned. These terms do not affect the Buyer's statutory rights.

R&G RACING RETURNS POLICY (NON-FAULTY GOODS)

Returns must be pre-authorized (if not pre-authorized the return will be rejected). Goods may only be returned direct to us if they were purchased direct from us (customer must prove if necessary). Otherwise to be returned to original vendor. Goods must be in re-sellable condition, in the opinion of R&G Racing. All returns are subject to a 25% restocking and handling fee (25% of the gross value exc. P&P – at the prevailing price at time of purchase). The customer must pay any and all carriage charges. No returns of discontinued products, unless within 14 days of purchase. This policy does not affect your statutory rights and does not refer to faulty goods.

R&G Racing

Unit 1, Shelley's Lane, East Worldham, Alton, Hampshire, GU34 3AQ

Tel: +44 (0)1420 89007 Fax: +44 (0)1420 87301 www.rg-racing.com Email: info@rg-racing.com